

Flotation units with dissolved air ALPHA range

Flotation units with dissolved air allow to accelerate the separation of water and suspended solids. Compact and simple of use, they make it possible to recover at the same time floated and settling particles, and produce rejections with strong content of dry matter.

- Simple of use
- Compact construction
- Capacity for treatment: 2 to 30 m³/h according to the models
- Low cost of maintenance
- Recovery of the solids on the surface and at the bottom of the flotation unit
- Single system of drainage of the recovered solids

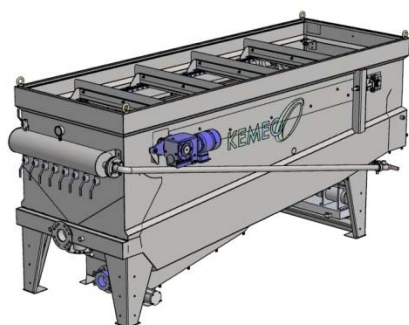

Applications:

Food industry (dairy, slaughter-houses, fish industry, factories of transformations,...)
 Petrochemical Industry
 Paper Industry
 Textile industry
 Urban plants
 Water treatment of ballast

	A (mm)	B (mm)	C (mm)	Débit (m ³ /h)
ALPHA 2	2400	900	1400	2
ALPHA 5	2400	1400	1400	5
ALPHA 10	3000	1650	1500	10
ALPHA 15	4000	1900	2350	15
ALPHA 20	4500	2400	2350	20
ALPHA 30	5000	2400	2350	30

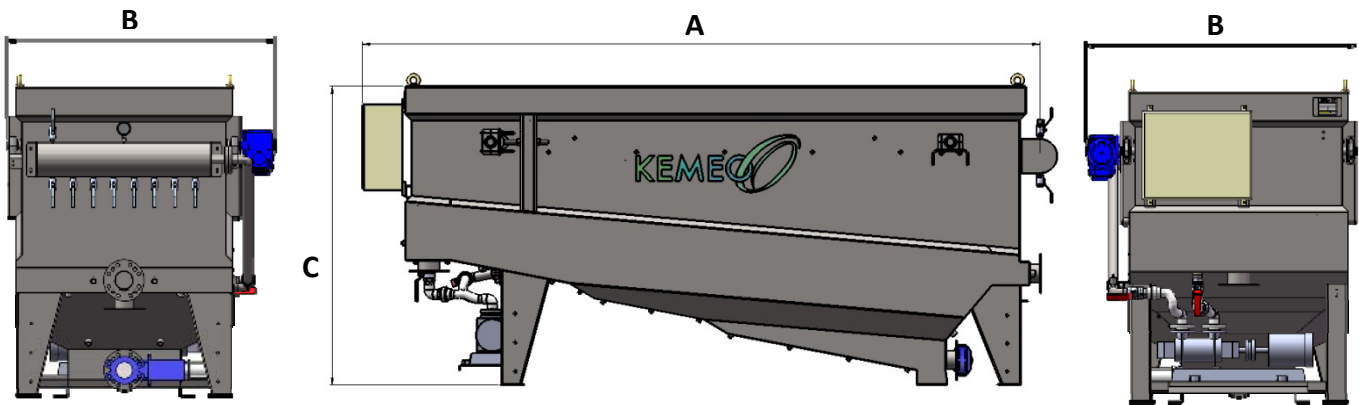

Operating principle:

